

ERASER DS™

SECONDARY CONVEYOR BELT CLEANING SYSTEM

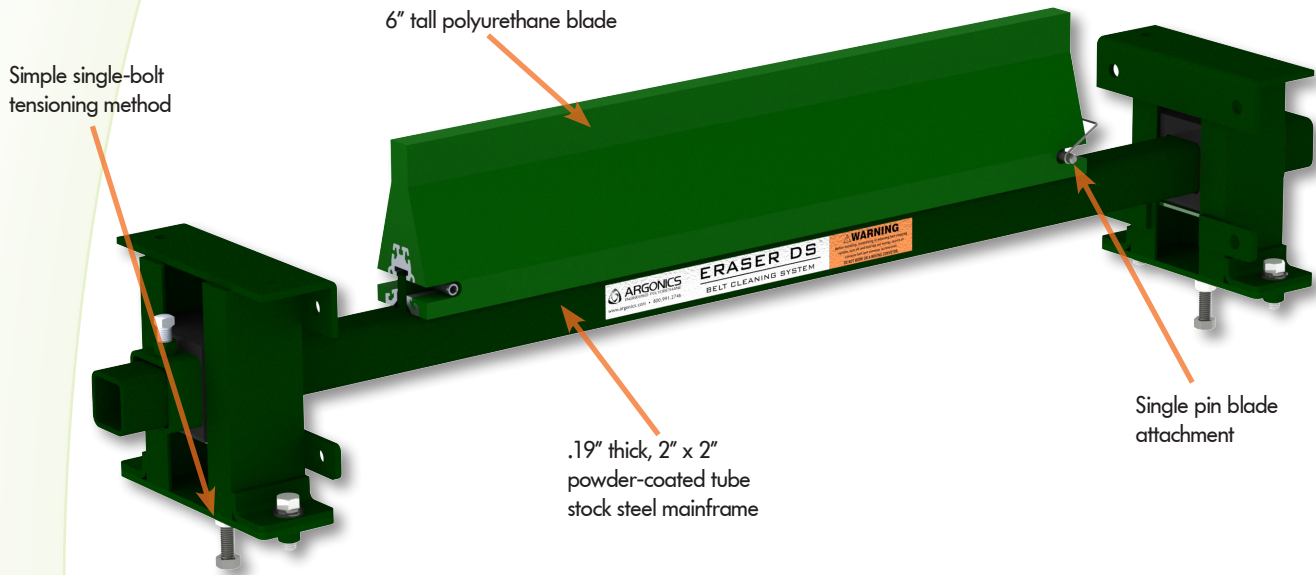







The Eraser DS is an economical version of our XTC cleaner, with a .19" thick (5 mm), 2" x 2" (51 mm x 51 mm) powder-coated tube stock steel mainframe for strength and durability. It is specifically designed for reversing conveyor belt applications. The DS uses the same polyurethane and tungsten carbide blades as the XTC.



BENEFITS

- Specifically designed for reversing conveyor belt applications
- Cleaning edges available in polyurethane and tungsten carbide
- No rusty springs, hoses, cables or shocks to deal with
- Single pin blade attachment means quick blade change out, less downtime and no rusty bolts

BLADES

 N62 Ether Normally used for extremely wet applications, sands & fines	 B93 Ester Our high temperature cleaning blade, up to 250°F (121°C)
 R80 Ether Good for wet applications with any pH level	 FO83 Ester MSHA approved, Frontline® Flame-resistant cleaning blade
 G83 Ester Our standard, high abrasion-resistant all-purpose blade	 RU83 Ester Flame-retardant, anti-static cleaning blade
 U90 Good for dry applications with any pH level	 Tungsten/Steel Tip Good for wet, sticky, or caked-on materials, up to 400°F (203°C)



ARGONICS
ENGINEERED POLYURETHANE

SIZING INFORMATION

Dimensions - in. (mm)

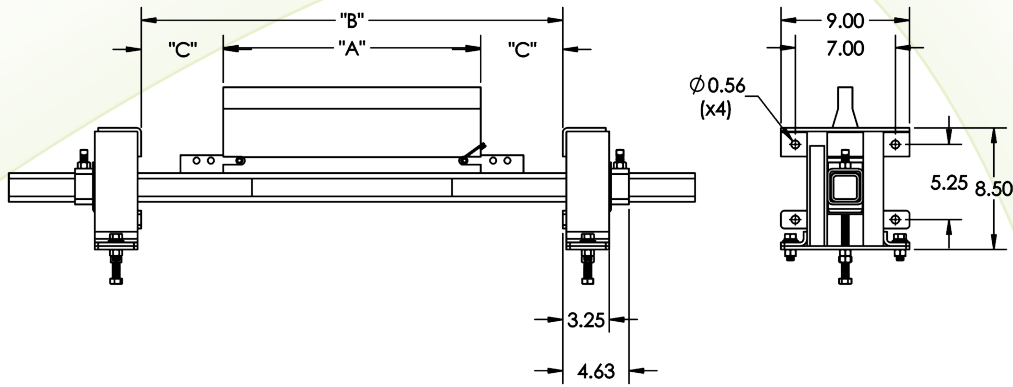

Part Number	A		Min B.		Max B.		Min C.		Max C.		Shipping Weight	
	inches	(mm)	inches	(mm)	inches	(mm)	inches	(mm)	inches	(mm)	lbs	(kg)
CP-DS-1812N-P-G83	12.00	(305)	19.00	(483)	32.75	(832)	3.50	(89)	10.38	(264)	55.65	(25)
CP-DS-2418N-P-G83	18.00	(457)	25.00	(635)	38.75	(984)	3.50	(89)	10.38	(264)	62.48	(28)
CP-DS-3024N-P-G83	24.00	(610)	31.00	(787)	44.75	(1137)	3.50	(89)	10.38	(264)	69.31	(31)
CP-DS-3630N-P-G83	30.00	(762)	37.00	(940)	50.75	(1289)	3.50	(89)	10.38	(264)	76.15	(35)
CP-DS-4236N-P-G83	36.00	(914)	43.00	(1092)	56.75	(1441)	3.50	(89)	10.38	(264)	82.98	(38)
CP-DS-4842N-P-G83	42.00	(1067)	49.00	(1245)	62.75	(1594)	3.50	(89)	10.38	(264)	89.81	(41)
CP-DS-5448N-P-G83	48.00	(1219)	55.00	(1397)	68.75	(1746)	3.50	(89)	10.38	(264)	96.65	(44)
CP-DS-6054N-P-G83	54.00	(1372)	61.00	(1549)	74.75	(1899)	3.50	(89)	10.38	(264)	103.58	(47)
CP-DS-7266N-P-G83	66.00	(1676)	73.00	(1854)	86.75	(2203)	3.50	(89)	10.38	(264)	117.15	(53)

NOTES:

- Systems are ordered by belt width and blades are 6" (152 mm) shorter than the belt width.

SPECIFICATIONS

Recommended Belt Speeds

Urethane blade: 0 - 500 fpm (2.54 m/s)

Tungsten blade: 0 - 750 fpm (3.81 m/s)

Mounting Distance

Vertical: 1" (25 mm) min. and 4" (102 mm) max.

Horizontal: up to 16" (406 mm)

MOUNTING INFORMATION

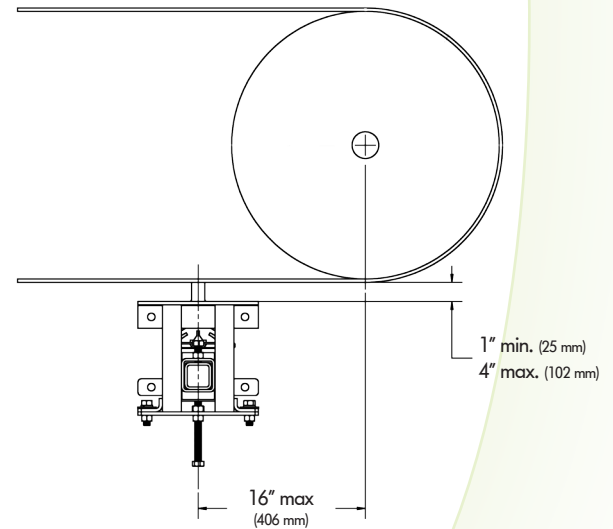

NOMENCLATURE

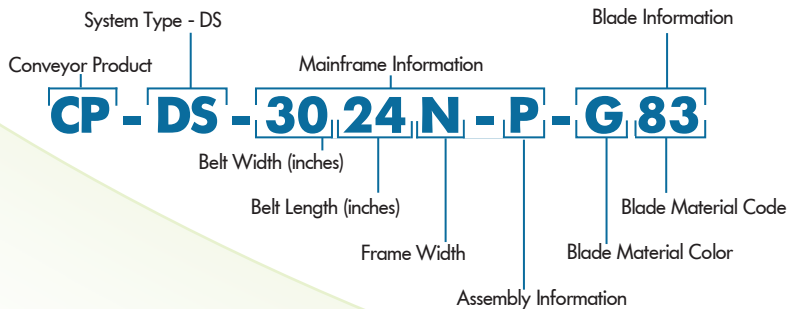

Notes:

- Tungsten system does not follow this nomenclature. Please contact your Argonics rep. for more information.



ARGONICS
ENGINEERED POLYURETHANE



Jamieson Equipment Company
www.jamiesonequipment.com
toll free 800.875.0280